



INTERNATIONAL TELECOMMUNICATION UNION

CCITT

V.32 *bis*

THE INTERNATIONAL
TELEGRAPH AND TELEPHONE
CONSULTATIVE COMMITTEE

**DATA COMMUNICATION
OVER THE TELEPHONE NETWORK**

**A DUPLEX MODEM OPERATING AT
DATA SIGNALLING RATES OF UP TO
14 400 bit/s FOR USE ON THE GENERAL
SWITCHED TELEPHONE NETWORK AND
ON LEASED POINT-TO-POINT 2-WIRE
TELEPHONE-TYPE CIRCUITS**

Recommendation V.32 *bis*



Geneva, 1991

FOREWORD

The CCITT (the International Telegraph and Telephone Consultative Committee) is a permanent organ of the International Telecommunication Union (ITU). CCITT is responsible for studying technical, operating and tariff questions and issuing Recommendations on them with a view to standardizing telecommunications on a worldwide basis.

The Plenary Assembly of CCITT which meets every four years, establishes the topics for study and approves Recommendations prepared by its Study Groups. The approval of Recommendations by the members of CCITT between Plenary Assemblies is covered by the procedure laid down in CCITT Resolution No. 2 (Melbourne, 1988).

Recommendation V.32 *bis* was prepared by Study Group XVII and was approved under the Resolution No. 2 procedure on the 22 of February 1991.

CCITT NOTE

In this Recommendation, the expression "Administration" is used for conciseness to indicate both a telecommunication Administration and a recognized private operating agency.

© ITU 1991

All rights reserved. No part of this publication may be reproduced or utilized in any form or by any means, electronic or mechanical, including photocopying and microfilm, without permission in writing from the ITU.

Recommendation V.32 bis

A DUPLEX MODEM OPERATING AT DATA SIGNALLING RATES OF UP TO 14 400 bit/s FOR USE ON THE GENERAL SWITCHED TELEPHONE NETWORK AND ON LEASED POINT-TO-POINT 2-WIRE TELEPHONE -TYPE CIRCUITS

1 Introduction

This modem is intended for use on connections on general switched telephone networks (GSTNs) and on point-to-point 2-wire leased telephone-type circuits. The principal characteristics of the modem are as follows:

- a) duplex mode of operation on GSTN and point-to-point 2-wire leased circuits;
- b) channel separation by echo cancellation techniques;
- c) quadrature amplitude modulation for each channel with synchronous line transmission at 2400 symbols/s;
- d) the following synchronous data signalling rates shall be implemented in the modem:
 - 14 400 bit/s trellis coded,
 - 12 000 bit/s trellis coded,
 - 9600 bit/s trellis coded,
 - 7200 bit/s trellis coded,
 - 4800 bit/s uncoded;
- e) compatibility with Recommendation V.32 modems at 9600 and 4800 bit/s;
- f) exchange of rate sequences during start-up to establish the data signalling rate;
- g) a procedure to change the data signalling rate without retraining.

Note 1 – On international GSTN connections that utilize circuits that are in accord with Recommendation G.235 (16-channel terminal equipments), it may be necessary to employ a greater degree of equalization within the modem than would be required for use on most national GSTN connections.

Note 2 – The transmit and receive rates in each modem shall be the same. The possibility of asymmetric working remains for further study.

2 Line signals

2.1 *Carrier frequency and modulation rate*

The carrier frequency is to be 1800 ± 1 Hz. The receiver must be able to operate with a maximum received frequency offset of up to ± 7 Hz.

The modulation rate shall be 2400 symbols/s $\pm 0.01\%$.

2.2 *Transmitted spectrum*

The transmitted power level must conform to Recommendation V.2. With continuous binary ones applied to the input of the scrambler, the transmitted energy density at 600 Hz and 3000 Hz shall be attenuated 4.5 ± 2.5 dB with respect to the maximum energy density between 600 Hz and 3 000 Hz.

2.3 Coding

2.3.1 Signal element coding for 14 400 bit/s

At 14 400 bits per second, the scrambled data stream to be transmitted is divided into groups of six consecutive data bits. The first two bits in time $Q1_n$ and $Q2_n$ in each group, where the subscript n designates the sequence number of the group, are first differentially encoded into $Y1_n$ and $Y2_n$ according to Table 1/V.32 bis. The two differentially encoded bits $Y1_n$ and $Y2_n$ are used as input to a systematic convolutional encoder which generates a redundant bit $Y0_n$ (see Figure 1/V.32 bis). This redundant bit and the six information-carrying bits $Y1_n$, $Y2_n$, $Q3_n$, $Q4_n$, $Q5_n$, $Q6_n$ are then mapped into the coordinates of the signal element to be transmitted according to the signal space diagram shown in Figure 2-1/V.32 bis.

TABLE 1/V.32 bis

Differential quadrant coding with trellis coding

| Inputs | | Previous outputs | | Outputs | |
|--------|--------|------------------|------------|---------|--------|
| $Q1_n$ | $Q2_n$ | $Y1_{n-1}$ | $Y2_{n-1}$ | $Y1_n$ | $Y2_n$ |
| 0 | 0 | 0 | 0 | 0 | 0 |
| 0 | 0 | 0 | 1 | 0 | 1 |
| 0 | 0 | 1 | 0 | 1 | 0 |
| 0 | 0 | 1 | 1 | 1 | 1 |
| 0 | 1 | 0 | 0 | 0 | 1 |
| 0 | 1 | 0 | 1 | 0 | 0 |
| 0 | 1 | 1 | 0 | 1 | 1 |
| 0 | 1 | 1 | 1 | 1 | 0 |
| 1 | 0 | 0 | 0 | 1 | 0 |
| 1 | 0 | 0 | 1 | 1 | 1 |
| 1 | 0 | 1 | 0 | 0 | 1 |
| 1 | 0 | 1 | 1 | 0 | 0 |
| 1 | 1 | 0 | 0 | 1 | 1 |
| 1 | 1 | 0 | 1 | 1 | 0 |
| 1 | 1 | 1 | 0 | 0 | 0 |
| 1 | 1 | 1 | 1 | 0 | 1 |

2.3.2 Signal element coding for 12 000 bit/s

At 12 000 bits per second, the scrambled data stream to be transmitted is divided into groups of five consecutive data bits. The first two bits in time $Q1_n$ and $Q2_n$ in each group, where the subscript n designates the sequence number of the group, are first differentially encoded into $Y1_n$ and $Y2_n$ according to Table 1/V.32 bis. The two differentially encoded bits $Y1_n$ and $Y2_n$ are used as input to a systematic convolutional encoder which generates a redundant bit $Y0_n$ (see Figure 1/V.32 bis). This redundant bit and the five information-carrying bits $Y1_n$, $Y2_n$, $Q3_n$, $Q4_n$, $Q5_n$, are then mapped into the coordinates of the signal element to be transmitted according to the signal space diagram shown in Figure 2-2/V.32 bis.

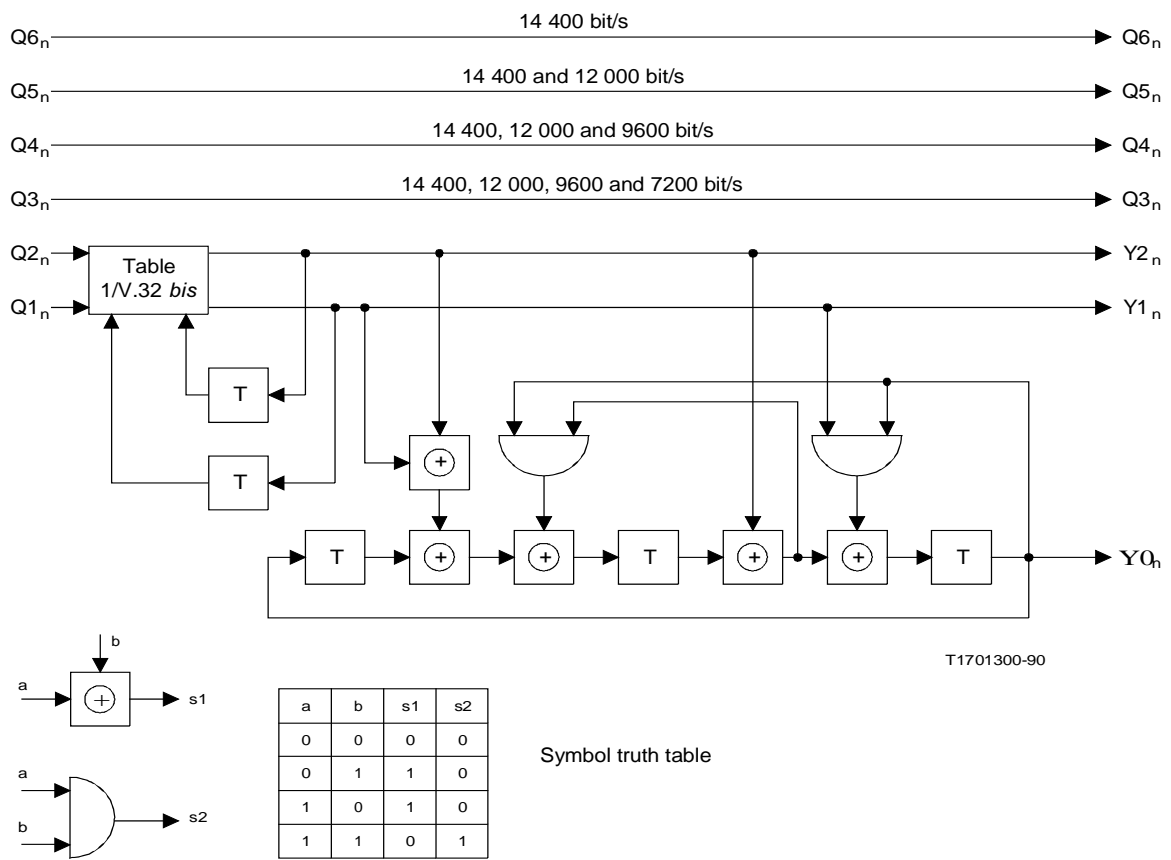
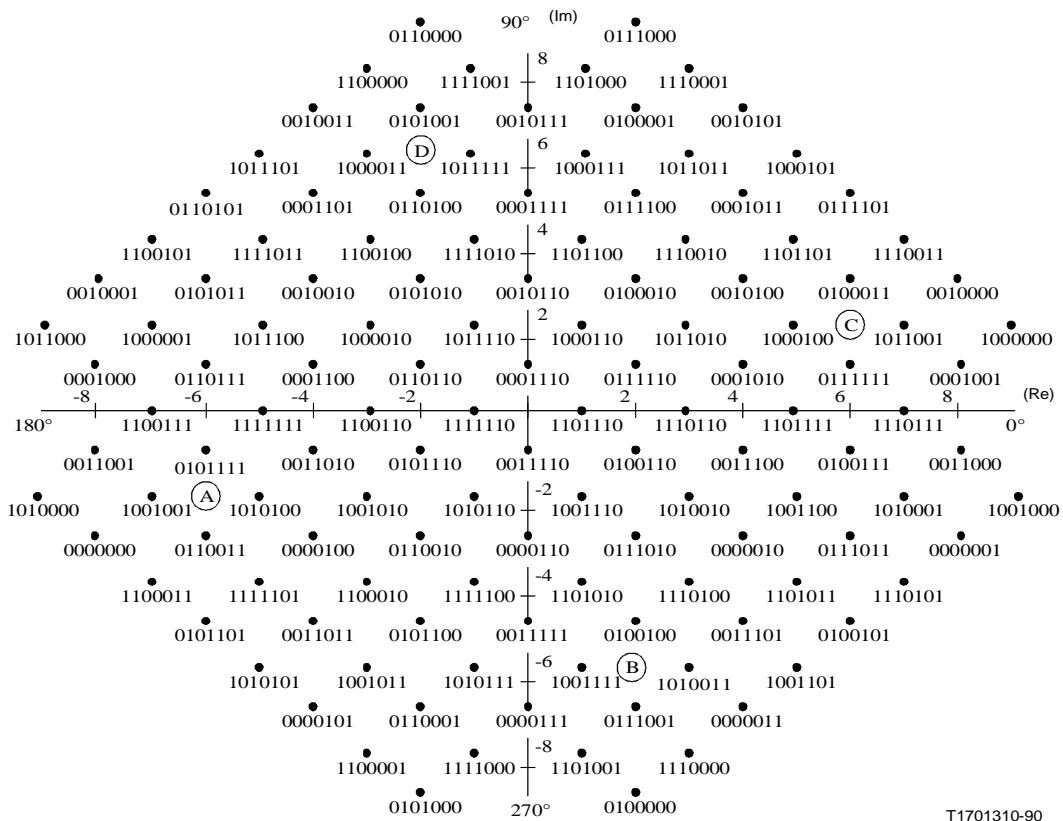

FIGURE 1/V.32 bis
Trellis encoder



T1701310-90

Note – Binary numbers refer to $Y0_n, Y1_n, Y2_n, Q3_n, Q4_n, Q5_n, Q6_n$.
 A, B, C, D refer to synchronizing signal elements.

FIGURE 2-1/V.32 bis

Signal space diagram and mapping for modulation at 14 400 bit/s per second

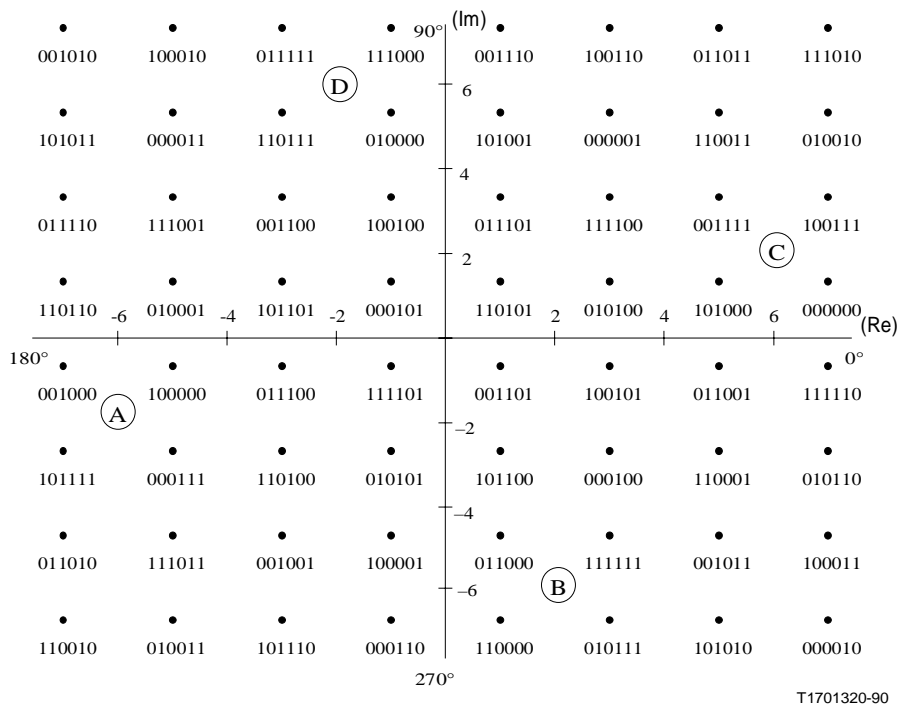

T1701320-90

Note – Binary numbers refer to Y_0 , Y_1 , Y_2 , Q_3 , Q_4 , Q_5 .
 A, B, C, D refer to synchronizing signal elements.

FIGURE 2-2/V.32 bis

Signal space diagram and mapping for modulation at 12 000 bit/s per second

2.3.3 Signal element coding for 9600 bit/s

At 9600 bits per second, the scrambled data stream to be transmitted is divided into groups of four consecutive data bits. The first two bits in time $Q1_n$ and $Q2_n$ in each group, where the subscript n designates the sequence number of the group, are first differentially encoded into $Y1_n$ and $Y2_n$ according to Table 1/V.32 bis. The two differentially encoded bits $Y1_n$ and $Y2_n$ are used as input to a systematic convolutional encoder which generates a redundant bit $Y0_n$ (see Figure 1/V.32 bis). This redundant bit and the four information-carrying bits $Y1_n$, $Y2_n$, $Q3_n$, $Q4_n$, are then mapped into the coordinates of the signal element to be transmitted according to the signal space diagram shown in Figure 2-3/V.32 bis.

2.3.4 Signal element coding for 7200 bit/s

At 7200 bits per second, the scrambled data stream to be transmitted is divided into groups of three consecutive data bits. The first two bits in time $Q1_n$ and $Q2_n$ in each group, where the subscript n designates the sequence number of the group, are first differentially encoded into $Y1_n$ and $Y2_n$ according to Table 1/V.32 bis. The two differentially encoded bits $Y1_n$ and $Y2_n$ are used as input to a systematic convolutional encoder which generates a redundant bit $Y0_n$ (see Figure 1/V.32 bis). This redundant bit and the three information-carrying bits $Y1_n$, $Y2_n$, $Q3_n$, are then mapped into the coordinates of the signal element to be transmitted according to the signal space diagram shown in Figure 2-4/V.32 bis.

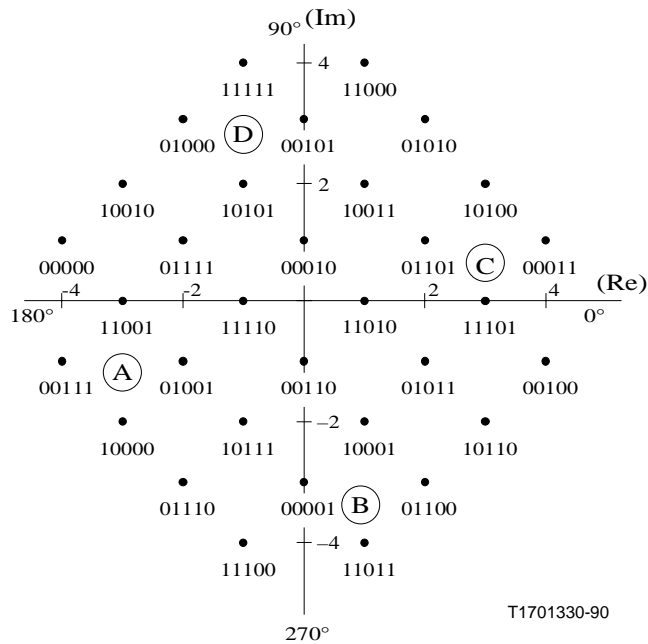

Note – Binary numbers refer to $Y_0^n, Y_1^n, Y_2^n, Q_3^n, Q_4^n$.
 A, B, C, D refer to synchronizing signal elements.

FIGURE 2-3/V.32 bis
 Signal space diagram and mapping for modulation at 9600 bit/s per second

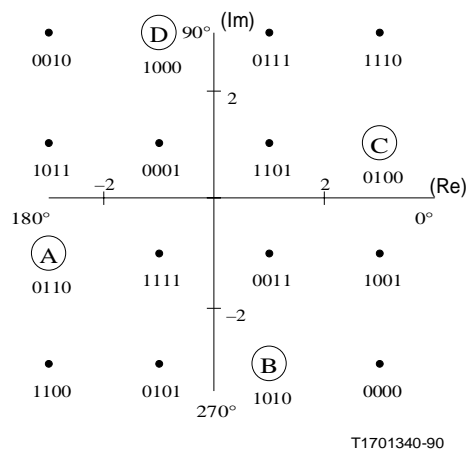

Note – Binary numbers refer to Y_0^n, Y_1^n, Y_2^n .
 A, B, C, D refer to synchronizing signal elements.

FIGURE 2-4/V.32 bis
 Signal space diagram and mapping for modulation at 7200 bit/s per second

2.3.5 Signal element coding for 4800 bit/s

At 4800 bits per second, the scrambled data stream to be transmitted is divided into groups of two consecutive data bits. The two bits $Q1_n$ and $Q2_n$, where $Q1_n$ is first in time, where the subscript n designates the sequence number of the group, are first differentially encoded into $Y1_n$ and $Y2_n$ according to Table 2/V.32 bis. The two differentially encoded bits $Y1_n$ and $Y2_n$ are then mapped into the coordinates of the signal element to be transmitted according to the signal space diagram shown in Figure 2-5/V.32 bis.

TABLE 2/V.32 bis
Differential quadrant coding for 4800 bit/s

| Inputs | | Previous outputs | | Phase quadrant change | Outputs | | Signal state for 4800 bit/s |
|--------|--------|------------------|------------|-----------------------|---------|--------|-----------------------------|
| $Q1_n$ | $Q2_n$ | $Y1_{n-1}$ | $Y2_{n-1}$ | | $Y1_n$ | $Y2_n$ | |
| 0 | 0 | 0 | 0 | +90° | 0 | 1 | B |
| 0 | 0 | 0 | 1 | | 1 | 1 | C |
| 0 | 0 | 1 | 0 | | 0 | 0 | A |
| 0 | 0 | 1 | 1 | | 1 | 0 | D |
| 0 | 1 | 0 | 0 | 0° | 0 | 0 | A |
| 0 | 1 | 0 | 1 | | 0 | 1 | B |
| 0 | 1 | 1 | 0 | | 1 | 0 | D |
| 0 | 1 | 1 | 1 | | 1 | 1 | C |
| 1 | 0 | 0 | 0 | +180° | 1 | 1 | C |
| 1 | 0 | 0 | 1 | | 1 | 0 | D |
| 1 | 0 | 1 | 0 | | 0 | 1 | B |
| 1 | 0 | 1 | 1 | | 0 | 0 | A |
| 1 | 1 | 0 | 0 | +270° | 1 | 0 | D |
| 1 | 1 | 0 | 1 | | 0 | 0 | A |
| 1 | 1 | 1 | 0 | | 1 | 1 | C |
| 1 | 1 | 1 | 1 | | 0 | 1 | B |

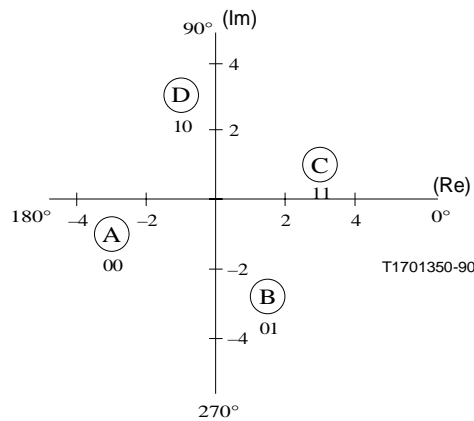

Note – Binary numbers refer to $Y1_n$ and $Y2_n$.
A, B, C, D refer to synchronizing signal elements.

FIGURE 2-5/V.32 bis
Signal space diagram and mapping for modulation at 4800 bit/s per second

3 DTE interface

When a standardized physical interface for the interchange circuits is not present, the equivalent functionality of the circuits must still be provided (see Table 3/V.32 *bis*).

TABLE 3/V.32 *bis*

| Interchange circuit | | |
|---------------------|--|--------|
| No. | Description | |
| 102 | Signal ground or common return | |
| 103 | Transmitted data | |
| 104 | Received data | |
| 105 | Request to send | |
| 106 | Ready for sending | |
| 107 | Data set ready | |
| 108/1 or | Connect data set to line | Note 1 |
| 108/2 | Data terminal ready | Note 1 |
| 109 | Data channel received line signal detector | |
| 113 | Transmitter signal element timing (DTE source) | Note 2 |
| 114 | Transmitter signal element timing (DCE source) | Note 3 |
| 115 | Receiver signal element timing (DCE source) | Note 3 |
| 125 | Calling indicator | |
| 140 | Loopback/maintenance | |
| 141 | Local loopback | |
| 142 | Test indicator | |

Note 1 – This circuit shall be capable of operation as circuit 108/1 or circuit 108/2 depending on its use. Operation of circuits 107 and 108/1 shall be in accordance with § 4.4 of Recommendation V.24.

Note 2 – When the modem is not operating in a synchronous mode at the interface, any signals on this circuit shall be disregarded. Many DTEs operating in an asynchronous mode do not have a generator connected to this circuit.

Note 3 – When the modem is not operating in a synchronous mode at the interface, this circuit shall be clamped to the OFF condition. Many DTEs operating in an asynchronous mode do not terminate this circuit.

3.1 Synchronous interfacing

The modems shall accept synchronous data from the DTE on circuit 103 (see Recommendation V.24) under control of circuit 113 or 114. The modem shall pass synchronous data to the DTE on circuit 104 under the control of circuit 115. The modem shall provide to the DTE, a clock on circuit 114 for transmit-data timing, and a clock on circuit 115 for receive-data timing. The transmit-data timing may, however, originate in the DTE and be transferred to the modem via circuit 113. In some applications, it may be necessary to slave the transmitter timing to the receiver timing inside the modem.

After the start-up and retrain sequences, circuit 106 must follow the state of circuit 105 within 2 ms.

OFF to ON and ON to OFF transitions of circuit 109 should occur solely in accordance with the operating sequences defined in § 5. Thresholds and response times are inapplicable because a line signal detector cannot be expected to distinguish wanted received signals from unwanted talker echos.

3.2 *Asynchronous character-mode interfacing*

The modulation process operates synchronously. However, the modem may be associated with an asynchronous to synchronous conversion entity interfacing to the DTE in an asynchronous (or start-stop character) mode. The protocol for conversion shall be in accordance with Recommendations V.14 or V.42. Other facilities such as data compression may also be employed.

3.3 *Electrical characteristics of interchange circuits*

When a standardized physical interface is provided, the electrical characteristics conforming to Recommendation V.28 will normally be used. Alternatively, the electrical characteristics conforming to Recommendations V.10 and V.11 may be used. The connector and pole assignments specified by ISO 2110, corresponding to the electrical characteristics provided, shall be used.

3.4 *Fault condition on interchange circuits*

The DTE shall interpret a fault condition on circuit 107 as an OFF condition using failure detection type 1.

The DCE shall interpret a fault condition on circuits 105 and 108 as an OFF condition using failure detection type 1.

All other circuits not referred to may use failure detection types 0 or 1.

Note – See § 7 of Recommendation V.28 and § 11 of Recommendation V.10.

4 Scrambler and descrambler

A self-synchronizing scrambler/descrambler shall be included in the modem. Each transmission direction uses a different scrambler. The method of allocating the scramblers is described in § 4.1. According to the direction of transmission, the generating polynomial is:

Call mode modem generating polynomial: $(GPC) = 1 + x^{-18} + x^{-23}$, or

Answer mode modem generating polynomial: $(GPA) = 1 + x^{-5} + x^{-23}$

At the transmitter, the scrambler shall effectively divide the message data sequence by the generating polynomial. The coefficients of the quotients of this division, taken in descending order, form the data sequence which shall appear at the output of the scrambler. At the receiver, the received data sequence shall be multiplied by the scrambler generating polynomial to recover the message sequence.

4.1 *Scrambler/descrambler allocation*

On the general switched telephone network, the modem at the calling data station (call mode) shall use the scrambler with the GPC generating polynomial and the descrambler with the GPA generating polynomial. The modem at the answering data station (answer mode) shall use the scrambler with the GPA generating polynomial and the descrambler with the GPC generating polynomial. On point-to-point leased circuits or when calls are established on the GSTN by operators, call mode/answer mode designation will be by bilateral agreement between Administrations or users and the scrambler/descrambler allocation will be the same as used on the GSTN.

5 Operating procedures

5.1 *Recommendation V.25 automatic answering sequence*

The Recommendation V.25 automatic answering sequence shall be transmitted from the answer mode modem on GSTN connections. The transmission of the sequence may be omitted on point-to-point leased circuits. In this event, the modem shall initiate transmission as in the retrain procedure specified in § 7.

5.2 Receiver conditioning signal

The receiver conditioning signal shall be used in the start-up and retrain procedures defined in §§ 6 and 7 below. The signal consists of three segments:

5.2.1 Segment 1, denoted by S in Figures 3/V.32 bis and 4/V.32 bis consists of alternations between states A and B as shown in Figure 2-5/V.32 bis, for a duration of 256 symbol intervals.

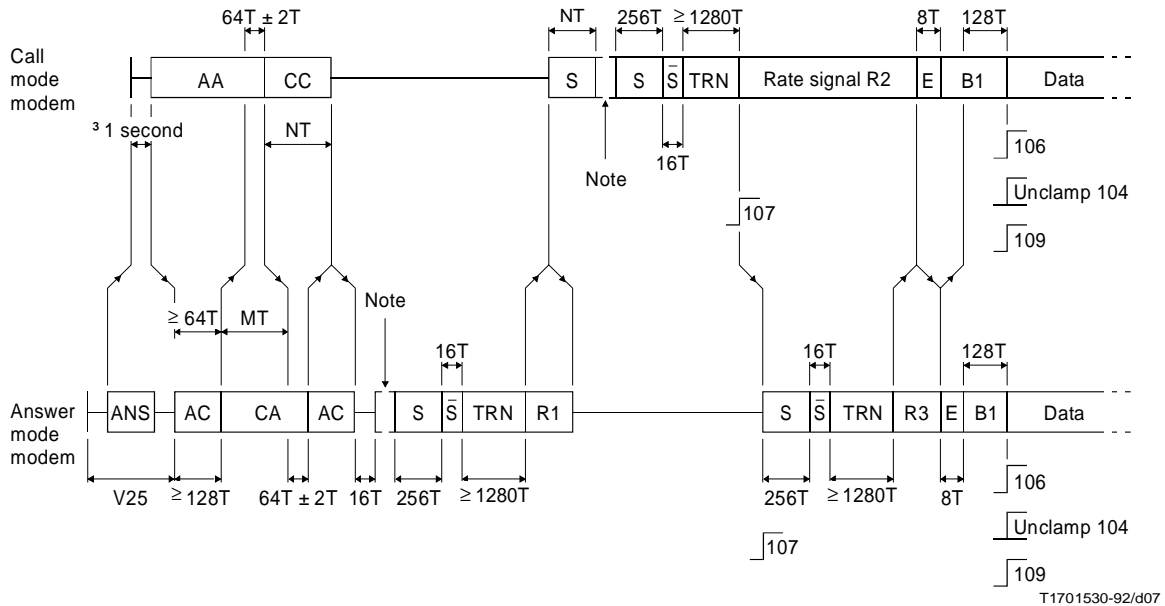

- AC Signal states ACAC..AC for an even number of symbol intervals T; similarly with CA, AA and CC
- MT, NT Round-trip delays observed from answer and call modems respectively, including $64T \pm 2T$ modem turn round delay
- S, \bar{S} Signal states ABAB..AB, CDCD..CD
- TRN Scrambled ones at 4800 bit/s with dibits encoded directly to states A, B, C and D as defined in § 5.2
- R1, R2, R3 Each a repeated 16-bit rate sequence at 4800 bit/s scrambled and differentially encoded as in Table 2/V.32bis
- E A single 16-bit sequence marking and following the end of a whole number of 16-bit rate sequences in R2 and R3
- B1 Binary ones scrambled and encoded as for the subsequent transmission of data

Note – The inclusion of a special echo canceller training sequence at this point is optional (see § 6, Note 3).

FIGURE 3/V.32 bis
Start-up procedure

5.2.2 Segment 2, denoted by \bar{S} in Figures 3/V.32 bis and 4/V.32 bis consists of alternations between states C and D as shown in Figure 2-5/V.32 bis, for a duration of 16 symbol intervals.

Note – The transition from segment 1 to segment 2 provides a well-defined event in the signal that may be used for generating a time reference in the receiver.

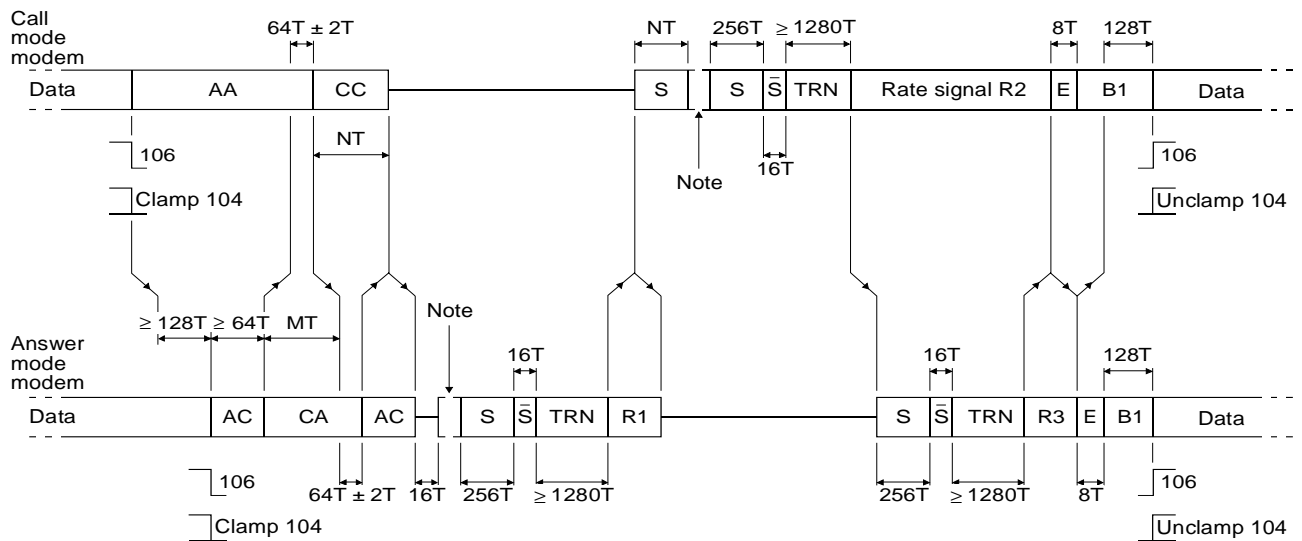

a) Retrain initiated by the calling modem

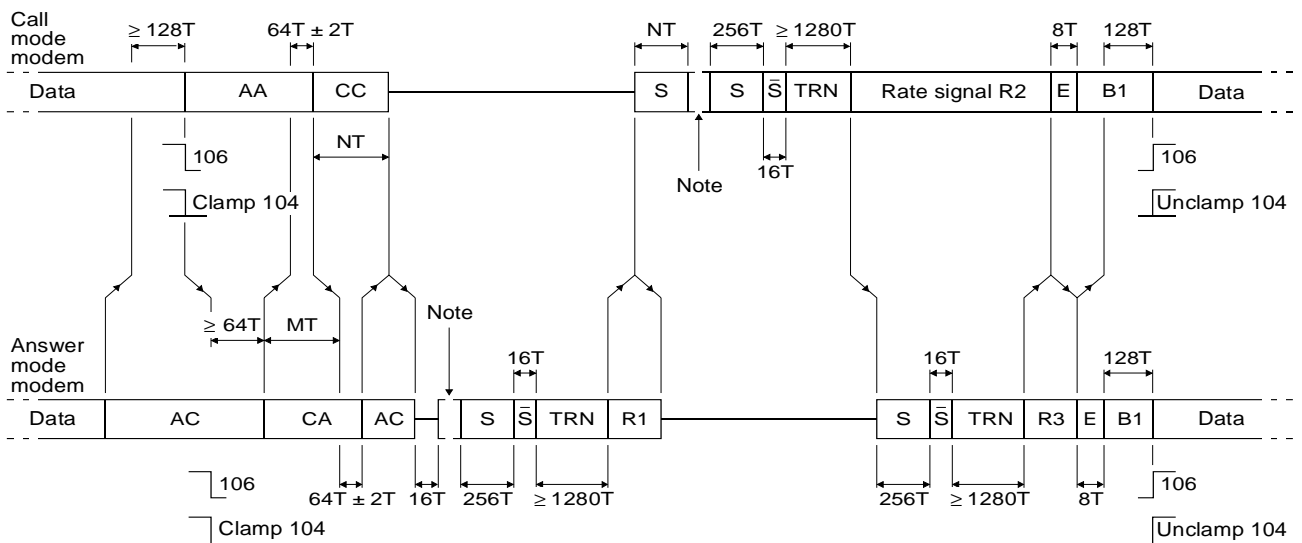

b) Retrain initiated by the answering modem

T1701540-92/d08

- AC Signal states ACAC..AC for an even number of symbol intervals T; similarly with CA, AA and CC
- MT, NT Round-trip delays observed from answer and call modems respectively, including $64T \pm 2T$ modem turn round delay
- S, S-bar Signal states ABAB..AB, CDCD..CD
- TRN Scrambled ones at 4800 bit/s with dibits encoded directly to states A, B, C and D as defined in § 5.2
- R1, R2, R3 Each a repeated 16-bit rate sequence at 4800 bit/s scrambled and differentially encoded as in Table 2/V.32bis
- E A single 16-bit sequence marking and following the end of a whole number of 16-bit rate sequences in R2 and R3
- B1 Binary ones scrambled and encoded as for the subsequent transmission of data

Note – The inclusion of a special echo canceller training sequence at this point is optional (see § 6, Note 3).

FIGURE 4/V.32 bis
Retrain procedure

5.2.3 Segment 3, denoted by TRN in Figures 3/V.32 *bis* and 4/V.32 *bis*, is a sequence derived by scrambling binary ones at a data rate of 4800 bit/s with the scrambler defined in § 4. During the transmission of this segment, the differential quadrant encoding shall be disabled. The initial state of the scrambler shall be all zeros, and a binary one applied to the input for the duration of segment 3. Successive dibits are encoded onto transmitted signal states.

The first 256 transmitted signal states are determined from the state of the first bit occurring (in time) in each dibit. When this bit is ZERO, signal state A is transmitted; when this bit is ONE, signal state C is transmitted. Depending on whether the modem is in call or answer mode, the scrambler output patterns and corresponding signal states will then begin as below, where the bits and the signal states are shown in time sequence from left to right.

Call mode modem:

GPC:, 11 11 11 11 11 11 11 11 11 00 00 01 11 11 11
 C C C C C C C C C A A A C C C

Answer mode modem:

GPA:, 11 11 10 00 00 11 11 10 00 00 11 10 01 11 11
 C C C A A C C C A A C C A C C

Immediately after 256 such symbols, successive scrambled dibits are encoded onto transmitted signal states in accordance with Table 4/V.32 *bis* directly without differential encoding for the remainder of segment 3. The duration of segment 3 shall be at least 1280 and not exceed 8192 symbol intervals.

Segment 3 is intended for training the adaptive equaliser in the receiving modem and the echo canceller in the transmitting modem.

TABLE 4/V.32 *bis*
**Encoding for TRN segment
 after the first 256 symbols**

| Dibit | Signal state |
|-------|--------------|
| 00 | A |
| 01 | B |
| 11 | C |
| 10 | D |

5.3 *Rate signal*

The rate signal shall be used in the start-up, retrain, and rate re-negotiating procedures.

The rate signal consists of a whole number of repeated 16-bit binary sequences, as defined in Table 5/V.32 *bis*, scrambled and transmitted at 4800 bit/s with dibits differentially encoded as in Table 2/V.32 *bis*. In the start-up and retrain procedures (see §§ 6 and 7), the differential encoder shall be initialized using the final symbol of the transmitted TRN segment.

In the rate renegotiation procedure (see § 8), the differential encoder shall be initialized using the final symbol of the transmitted preamble and the scrambler shall be initialized to all zeros.

The first two bits and each successive dibit of the rate sequence shall be encoded to form the transmitted signal states.

TABLE 5/V.32 *bis*
Coding of the rate signal

| | | | | | | | | | | | | | | | | | | | | | |
|---|---|---|---|---|---|---|---|---|---|----|----|----|----|----|----|---|---|---|---|---|-----|
| B | B | B | B | B | B | B | B | B | B | B | B | B | B | B | B | B | B | B | B | B | B |
| 0 | 1 | 2 | 3 | 4 | 5 | 6 | 7 | 8 | 9 | 10 | 11 | 12 | 13 | 14 | 15 | | B | B | B | B | ... |
| 0 | 0 | 0 | 0 | 1 | - | - | 1 | 1 | - | - | 1 | - | 0 | 0 | 1 | | 0 | 0 | 0 | 0 | |

B0-B3, B7, B11, B15 For synchronizing on a rate signal

B4 = 1 (Note 1)

B8 = 1 (Note 1)

B5 1 denotes that operation at 4800 bit/s rate is enabled

B6 1 denotes that operation at 9600 bit/s rate is enabled

B9 1 denotes that operation at 7200 bit/s rate is enabled

B10 1 denotes that operation at 12 000 bit/s rate is enabled

B12 1 denotes that operation at 14 400 bit/s rate is enabled

B13, B14 = 0, 0 (Note 2)

Note 1 – When B4 or B8 is set to zero, in a transmitted or received rate signal, then interworking can proceed only in accordance with Recommendation V.32.

Note 2 – B13 and B14 shall be set to zero when transmitting and ignored during the reception of a rate signal; they are reserved for future definition by the CCITT and must not be used by manufacturers.

Note 3 – B4-B6, B9-B10, B12 set to zero calls for a GSTN clear-down.

5.3.1 *Detecting a rate signal*

The minimum requirement for detection is the receipt of two consecutive identical 16-bit sequences each with bits B0-B3, B7, B11 and B15 conforming to Table 5/V.32 *bis*.

5.3.2 *Ending the rate signal*

In order to mark the end of transmission of any rate signal other than R1 (see Figure 3/V.32 *bis*), the modem shall first complete the transmission of the current 16-bit rate sequence, and then transmit one 16-bit sequence E, coded as shown in Table 6/V.32 *bis*.

TABLE 6/V.32 *bis*
Coding of sequence E

| | | | | | | | | | | | | | | | | |
|---|---|---|---|---|---|---|---|---|---|----|----|----|----|----|----|---|
| B | B | B | B | B | B | B | B | B | B | B | B | B | B | B | B | B |
| 0 | 1 | 2 | 3 | 4 | 5 | 6 | 7 | 8 | 9 | 10 | 11 | 12 | 13 | 14 | 15 | |
| 1 | 1 | 1 | 1 | 1 | - | - | 1 | 1 | - | - | 1 | - | 0 | 0 | 1 | |

B4-B12 as in Table 5/V.32 *bis* except the only data rate to be indicated shall relate to the transmission of scrambled binary ones immediately following signal E.

6 Start-up procedure

The procedure for achieving synchronism between the calling modem and the answering modem on international GSTN connections is shown in Figure 3/V.32 *bis*. The procedure includes the estimating of round-trip delay from each modem, the training of echo cancellers and receivers initially with half-duplex transmissions, and the exchanging of rate signals for automatic bit-rate and mode selection.

6.1 Call mode modem

After receiving the answer tone for a period of at least 1 s as specified in Recommendation V.25, the modem shall be connected to line (see Note 1 below) and shall condition the scrambler and descrambler in accordance with § 4.1.

The modem shall repetively transmit carrier state A as shown in Figure 2-5/V.32 *bis*.

The modem shall be conditioned to detect (see Note 2 below) one of two incoming tones at frequencies 600 ± 7 Hz and 3000 ± 7 Hz, and subsequently to detect a phase reversal in that tone.

On detection of one such phase reversal, the modem shall be conditioned to detect a second phase reversal in the same tone, start a counter/timer and change to repetively transmitting state C as shown in Figure 2-5/V.32 *bis*. The time delay between the reception of this phase reversal at the line terminals and the transmitted AA to CC transition appearing at the line terminals shall be 64 ± 2 symbol periods.

On detection of a second phase reversal in the same incoming tone, the modem shall stop the counter/timer and cease transmitting.

When the modem detects an incoming S sequence (see § 5.2), it shall proceed to train its receiver, and then seek to detect at least two consecutive identical 16-bit rate sequences as defined in Table 5/V.32 *bis*.

On detection of the rate signal (R1), the modem shall transmit an S sequence for a period NT already estimated by the counter/timer.

After this period has expired (see Note 3 below), the modem shall transmit the receiver conditioning signal as defined in § 5.2, starting with an S sequence for 256 symbol intervals.

Transmission of the TRN segment of the receiver conditioning signal may be extended in order to ensure a satisfactory level of echo cancellation (see Note 4 below).

After the TRN segment, the modem shall apply an ON condition to circuit 107 and transmit a rate signal (R2) in accordance with § 5.3 to indicate the currently available data rates. R2 shall exclude rates not appearing in the previously received rate signal R1. It is recommended that R2 take also account of the likely receiver performance with the particular GSTN connection. If it appears that satisfactory performance cannot be attained at any of the available data rates, then R2 should be used to call for a GSTN clear-down in accordance with Table 5/V.32 *bis*.

Transmission of R2 shall continue until an incoming rate signal R3 is detected. The modem shall then, after completing its current 16-bit rate sequence, transmit a single 16-bit sequence E in accordance with § 5.3.2 indicating the data rate called for in R3. If, however, R3 is calling for GSTN clear-down in accordance with Table 5/V.32 *bis*, then the call modem shall disconnect from line and effect a clear-down.

The modem shall then transmit continuous scrambled binary ones at the data rate called for in R3. If trellis coding is to be used, the initial states of the delay elements of the convolution encoder shown in Figure 1/V.32 *bis* shall be set to zero.

On detecting an incoming 16-bit E sequence as defined in § 5.3.2, the modem shall condition itself to receive data at the rate indicated by the incoming E sequence. After a delay of 128 symbol intervals, it shall apply an ON condition to circuit 109, and unclamp circuit 104.

The modem shall then enable circuit 106 to respond to the condition of circuit 105 and be ready to transmit data.

6.2 Answer mode modem

On connection to line, the modem shall condition the scrambler and descrambler in accordance with § 4.1, and transmit the Recommendation V.25 answer sequence. Means, defined in Recommendation V.25, of disabling network cancellers and/or truncating the answer tone may be employed.

After the Recommendation V.25 answer sequence, the modem shall transmit alternate carrier states A and C as shown in Figure 2-5/V.32 *bis*.

After alternate states A and C have been transmitted for an even number of symbol intervals greater than or equal to 128 *and* an incoming tone has been detected at 1800 ± 7 Hz for 64 symbol periods (see Note 5 below), the modem shall be conditioned to detect a phase reversal in the incoming tone, start a counter/timer, and change to transmitting alternate carrier states C and A for an even number of symbol intervals.

On detecting a phase reversal in the incoming tone, the modem shall stop the counter/timer and, after transmitting a state A, revert to transmitting alternate states A and C. The time delay between the reception of this phase reversal at the line terminals and the transmitted CA to AC transition appearing at the line terminals shall be 64 ± 2 symbol periods.

When an amplitude drop is detected in the incoming tone, the modem shall cease transmitting for a period of 16 symbol intervals and then (see Note 3 below) transmit the receiver conditioning signal as defined in § 5.2.

Transmission of the TRN segment of the receiver conditioning signal may be extended in order to ensure a satisfactory level of echo cancellation (see Note 4 below).

After the TRN segment, the modem shall transmit a rate signal (R1) in accordance with § 5.3 to indicate the data rates currently available in the answer modem and associated DTE.

On detection of an incoming S sequence, the modem shall cease transmitting.

The modem shall wait for a period MT already estimated by the counter/timer and then, if an incoming S sequence persists, or when an S sequence reappears (see Note 3 below), the modem shall proceed to train its receiver.

After training its receiver, the modem shall seek to detect at least two consecutive identical incoming 16-bit rate sequences as defined in § 5.3.

On detection of a rate signal (R2), the modem shall apply an ON condition to circuit 107 and transmit a second receiver conditioning signal as defined in § 5.2.

After the TRN segment, the modem shall transmit a second rate signal (R3) in order to indicate the data rate to be used by both modems. The data rate selected by R3 shall be within those indicated by R2. It is recommended that R3 take also account of the likely performance of the answer modem receiver with the particular GSTN connection established. If R2 is calling for a GSTN clear-down (see Table 5/V.32 *bis*) and/or if it appears that satisfactory performance cannot be attained by the answer modem at any of the available data rates, then R3 should call for a GSTN clear-down, in accordance with Table 5/V.32 *bis* (see Note 6 below).

When the modem detects an incoming 16-bit E sequence as defined in § 5.3.2, it shall condition itself to receive data at the rate indicated by the E sequence.

The modem shall complete the current 16-bit rate sequence and then transmit a single 16-bit E sequence indicating the data rate to be used in the subsequent transmission of scrambled binary ones. If trellis coding is to be used, then the initial states of the delay elements of the convolution encoder shown in Figure 1/V.32 *bis* shall be set to zero.

The modem shall transmit scrambled binary ones for 128 symbol intervals, then enable circuit 106 to respond to the condition of circuit 105 and be ready to transmit data.

The modem shall also apply an ON condition to circuit 109 and unclamp circuit 104.

Notes to § 6

Note 1 – Once an incoming tone is detected at 600 ± 7 Hz or 3000 ± 7 Hz, the calling modem may proceed with the start-up sequence even if no 2100 Hz tone has been detected.

Note 2 – In some cases, the incoming tones may be preceded by a special pattern which may last up to 3100 ms.

Note 3 – The TRN segment in the receiver conditioning signal is suitable for training the echo canceller in the transmitting modem. Alternatively, it is acceptable to precede the receiver conditioning signal by a sequence which can be used specially for training the echo canceller, but which need not be defined in detail in the Recommendation. The echo cancellation sequence (if used) must maintain energy transmitted to line to hold network echo control devices disabled (as required). In order to avoid confusion with Segments 1 or 2 of the receiver conditioning signal defined in § 5.2, the echo cancellation sequence shall produce a transmitted signal such that the sum of its power in the three 200 Hz bands centred at 600 Hz, 1800 Hz and 3000 Hz is at least 1 dB less than its power in the remaining bandwidth. This applies for the relative power averaged over any 6 ms time interval. The duration of this signal must not exceed 8192 symbol intervals.

Note 4 – Manufacturers are cautioned that a period of 650 ms is needed for training any network echo cancellers conforming to Recommendation G.165, that may be encountered on GSTN connections.

Note 5 – The answering modem may disconnect from the line if the 1800 ± 7 Hz tone is not detected following transmission of the segment AC. However, to assure compatibility with manual originating data stations, it shall not disconnect for at least 3 seconds after the segment AC has been transmitted.

Note 6 – If R3 is calling for a GSTN clear-down, the modem shall repeat the transmission of signal R3 for not less than 64 symbol intervals before clearing the connection.

7 Retrain procedure

A retrain may be initiated during data transmission if either modem incorporates a means of detecting unsatisfactory signal reception. Figure 4a)/V.32 *bis* shows a retrain event initiated by the calling modem and Figure 4b)/V.32 *bis* shows a retrain event initiated by the answering modem. The procedure is as follows:

7.1 Call mode modem

Following detection of unsatisfactory signal reception or detection of one of two tones at frequencies 600 ± 7 Hz and 3000 ± 7 Hz for more than 128 symbol intervals, the modem shall turn OFF circuit 106, clamp circuit 104 to binary one and repetitively transmit carrier state A as shown in Figure 2-5/V.32 *bis*. It shall then proceed in accordance with § 6.1 beginning with the third paragraph.

7.2 Answer mode modem

Following detection of unsatisfactory signal reception or detection of a tone of frequency 1800 ± 7 Hz for more than 128 symbol intervals the modem shall turn OFF circuit 106, clamp circuit 104 to binary one and transmit alternate carrier states A and C for an even number of symbol intervals not less than 128. It shall then proceed in accordance with § 6.2 beginning with the third paragraph.

7.3 Operation of circuits 107 and 109 during retrain procedure

Circuit 107 shall be maintained in the ON condition during the retrain procedure.

Circuit 109 shall be maintained in the ON condition except that the OFF condition may optionally be applied if transmission of the AA segment in the call modem or of the first AC segment in the answer modem continues for a period exceeding 45 seconds. If the retrain procedure is subsequently completed, the ON condition shall be re-applied to circuit 109 at the time that circuit 104 is unclamped.

8 Rate renegotiating procedure

The following procedure shall be provided to enable modems to change their data signalling rate without retraining. Either modem may transmit a proposal for a desired data signalling rate. The proposal comprises a preamble followed by a rate code.

The preamble transmitted by the call mode modem consists of signal AA for a period of 56T followed by signal CC for a period 8T. The preamble transmitted by the answer mode modem consists of signal AC for a period 56T followed by signal CA for a period 8T.

The rate signal is as defined in § 5.3. The initial state of the scrambler shall be all zeros and the differential encoder shall be initialized using the final symbol of the transmitted preamble.

The rate renegotiating procedure is shown in Figure 5/V.32 bis. Figure 5a)/V.32 bis shows the procedure as initiated by the calling modem; Figure 5b)/V.32 bis shows the procedure as initiated by the answering modem.

8.1 Initiating procedure

Rate renegotiation may be initiated at any time during data transmission.

When a data signalling rate change is desired, the initiating modem shall turn circuit 106 OFF and transmit the appropriate preamble followed by a rate signal R4. R4 shall indicate the desired rate in the initiating modem and all lower data signalling rates at which the initiating modem is enabled to operate.

Following detection of the preamble (this might occur during the transmission of a preamble if both modems initiate the procedure almost simultaneously), the initiating modem shall clamp circuit 104 to binary one and condition its receiver to detect rate signal R5.

On detection of rate signal R5, the initiating modem shall condition its receiver to detect sequence E. Then, when R4 has been transmitted for a minimum of 64T, it shall complete the current 16-bit rate signal R4 and transmit sequence E in accordance with § 5.3.2 indicating the highest data signalling rate common to R4 and R5 (see Notes 1, 2 below). The initiating modem shall then transmit scrambled binary ones at this data signalling rate for 24T. The initial state of the convolutional encoder delay elements shall be zero. The initiating modem shall then enable circuit 106 to respond to the condition of circuit 105 and be ready to transmit data (see Note 3 below).

On detecting sequence E, the initiating modem shall condition itself to receive data at the highest data signalling rate common to both R4 and R5 and, after a delay of 24T, shall unclamp circuit 104.

8.2 Responding procedure

A modem shall be conditioned to detect an incoming preamble at any time while receiving data.

When a preamble is detected, the responding modem shall clamp circuit 104 to binary one and shall condition its receiver to detect rate signal R4. On detection of R4, the responding modem shall turn circuit 106 OFF and shall transmit the appropriate preamble.

Following the transmission of the preamble, the responding modem shall begin transmitting signal R5. R5 shall indicate the desired rate in the responding modem and all lower data signalling rates at which the responding modem is enabled to operate irrespective of the rates indicated in R4 (see Note 2 below).

After R5 has been transmitted for a period of 64T, the responding modem shall transmit sequence E in accordance with § 5.3.2 indicating the highest signalling rate common to R4 and R5 (see Note 2 below). The modem shall then transmit scrambled binary ones at this data signalling rate for 24T. The initial state of the convolutional encoder delay elements shall be zero. The responding modem shall then enable circuit 106 to respond to the condition of the circuit 105 and be ready to transmit data.

On detecting sequence E, the responding modem shall condition itself to receive data at the highest data signalling rate common to both R4 and R5 and, after a delay of 24T, it shall unclamp circuit 104.

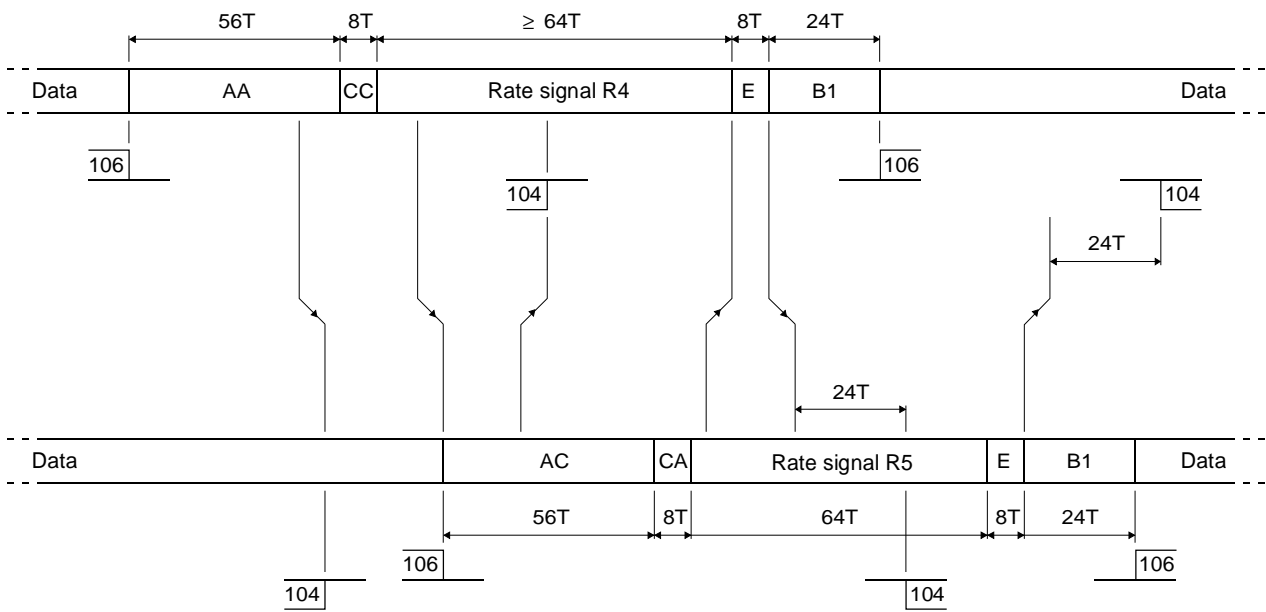

a) Rate negotiation initiated by the calling modem

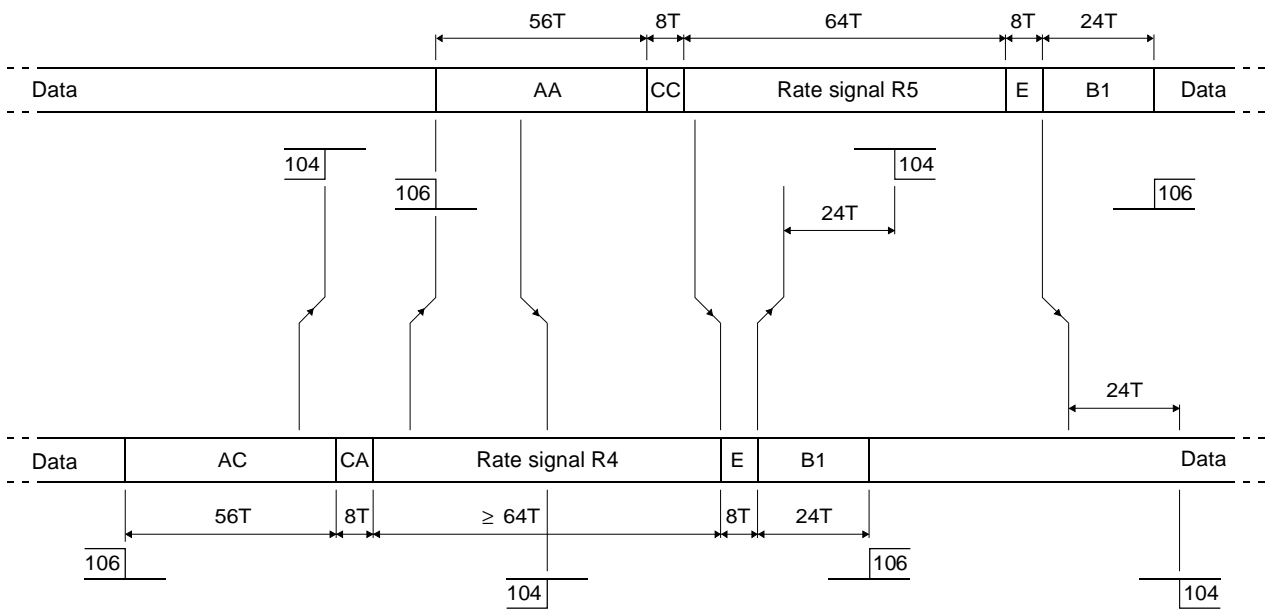

T1701550-92/d09

b) Rate negotiation initiated by the answering modem

FIGURE 5/V.32 bis
Rate negotiation procedure

Notes to § 8

Note 1 – If the highest data signalling rate indicated in R5 is less than the desired rate requested in R4, this may be either because line conditions do not permit the responding modem to operate currently at the desired rate or because this rate has been disabled in the responding modem. Both possibilities should be taken into account in determining the desirability of further rate renegotiation.

Note 2 – If R4 or R5 is calling for a GSTN clear-down in accordance with Table 5/V.32 *bis* or R4 and R5 have no rates in common, the modem shall complete the renegotiation procedure by repeating the transmission of sequence E for not less than 64T before clearing the connection.

Note 3 – If an attempt by the initiating modem to complete the rate renegotiation procedures is unsuccessful, it might be that the responding modem is a V.32 type modem that uses B4 for other purposes. The initiating modem should take this into consideration before attempting further rate renegotiation procedures.

9 Testing facilities

Test loops 2 and 3 as defined in Recommendation V.54 shall be provided. Provision for test loop 2 shall be as specified for point-to-point circuits.

ANNEX A

(to Recommendation V.32 *bis*)

Considering that there is a need for some V.32/V.32 *bis* modems to include the capability of interworking with V.22 and V.22 *bis* modems, the following start-up procedures are recommended. A modem which includes this optional capability will be referred to as an automode modem.

A.1 Definition of terms used

| | |
|------|--|
| ANS | The 2100 Hz answer tone defined in Recommendation V.25; |
| USB1 | Unscrambled binary ones modulated by an answering modem as defined in Recommendation V.22 <i>bis</i> ; |
| SB1 | Scrambled binary ones modulated as defined in Recommendation V.22 <i>bis</i> ; |
| S1 | Unscrambled double dibit 00 and 11 modulated as defined in Recommendation V.22 <i>bis</i> ; |
| AA | See Figures 4/V.32 and 3/V.32 <i>bis</i> ; |
| AC | See Figures 4/V.32 and 3/V.32 <i>bis</i> . |

A.2 Interworking of duplex modems

Modems conforming with Recommendations V.22 (operating at 1200 bit/s only), V.22 *bis*, V.32 and V.32 *bis* could interwork with a dedicated automode modem implementing a procedure for sensing the capabilities of a remote modem and employing the appropriate modulation scheme.

The procedure can follow two courses. The calling modem makes a decision as to whether its signal AA was detected by the answering modem during the V.25 answer sequence. If the decision indicates that signal AA was detected, the course followed is as depicted in Figure A-1/V.32 *bis*. Otherwise the course followed is as depicted in Figures A-2/V.32 *bis* and A-3/V.32 *bis*. Interworking with calling V.22 *bis* or V.22 modems is as depicted in Figure A-4/V.32 *bis*.

A.2.1 *Operation of the calling automode modem*

On connection to line, the calling modem shall initially remain silent and shall condition its receiver to detect any of three signals: AC, USB1, ANS.

A.2.1.1 If signal AC is detected, the modem shall begin transmission of signal AA and continue as defined in § 6.1 of this Recommendation.

A.2.1.2 If signal USB1 is detected, the modem shall start a timer.

When the elapsed time exceeds T_c , where $T_c > 3100$ ms, if signal USB1 is again detected, the modem shall first transmit signal S1 in the low band then begin transmitting signal SB1 and then continue with Recommendation V.22 *bis* beginning at § 6.3.1.1.c) of Recommendation V.22 *bis* (see Note 1). If at any time signal AC is detected, the modem shall continue as defined in § 6.1 of this Recommendation.

A.2.1.3 If signal ANS is detected for a period of at least 1 second, the modem shall begin transmission of signal AA, condition its receiver to prepare to detect either signal USB1 or signal AC, and start a timer to measure the duration of the remaining answer tone.

On the detection of the end of signal ANS, the timer is stopped. The timer value shall not include the 75 ms silent period defined in Recommendation V.25.

If, following the 75 ms silent period, signal AC is detected, the modem shall continue with the V.32 or V.32 *bis* training sequence beginning at § 6.1 of this Recommendation. When signal USB1 is detected for 155 ± 10 ms (see Note 2), subsequent procedures shall depend on the duration of signal ANS measured by the timer. If the duration was greater than 800 ms, the modem shall first stop transmitting AA, then, after 456 ms silent period, shall transmit signal S1 in the low band then begin transmitting signal SB1 and then continue with Recommendation V.22 *bis* beginning at § 6.3.1.1.c) of Recommendation V.22 *bis*. Otherwise, the modem shall proceed in accordance with § A.2.1.2.

A.2.2 *Operation of the answering automode modem*

On connection to line, the answering modem shall transmit the V.25 answer sequence and condition its receiver to detect signal AA.

If signal AA is detected at any time during the transmission of the V.25 answer sequence, the modem shall continue as defined in § 6.2 of this Recommendation at the second paragraph.

If signal AA is not detected during the transmission of the V.25 answer sequence, the modem shall begin transmitting signal USB1, condition its receiver to detect in the low band either of the two signals S1, SB1 and start a timer.

If either of the two signals S1, SB1 are detected in the low band, the modem shall continue as defined in Recommendation V.22 *bis* beginning at § 6.3.1.1.2b). Otherwise, when the elapsed time exceeds T_a , where $T_a = 3000 \pm 50$ ms (see Note 3), the modem shall proceed as defined in § 6.2 of this Recommendation beginning at the second paragraph.

Note 1 – There may be implementations of V.22 *bis* modems that terminate the transmission of USB1 before the elapsed time exceeds T_c because Recommendation V.22 *bis* does not specify a minimum timeout duration. These implementations may not interwork with this procedure.

Note 2 – There is a small possibility that some GSTN signalling systems could produce brief interruptions in transmission during a period in which signal AA may be inhibiting the effect of the 1800 Hz Rec. V.22 *bis*/V.22 guard tone transmitted with signal USB1.

Note 3 – The transmission of USB1 for this maximum duration is recommended in order to avoid signal AC being received and possibly misinterpreted as a loss of carrier by some implementations of V.22 *bis* modems. Some implementation of 1984 and 1988 V.32 modems might be sensitive to more than 294 ms of USB1 (see § 6, Note 2 of this Recommendation).

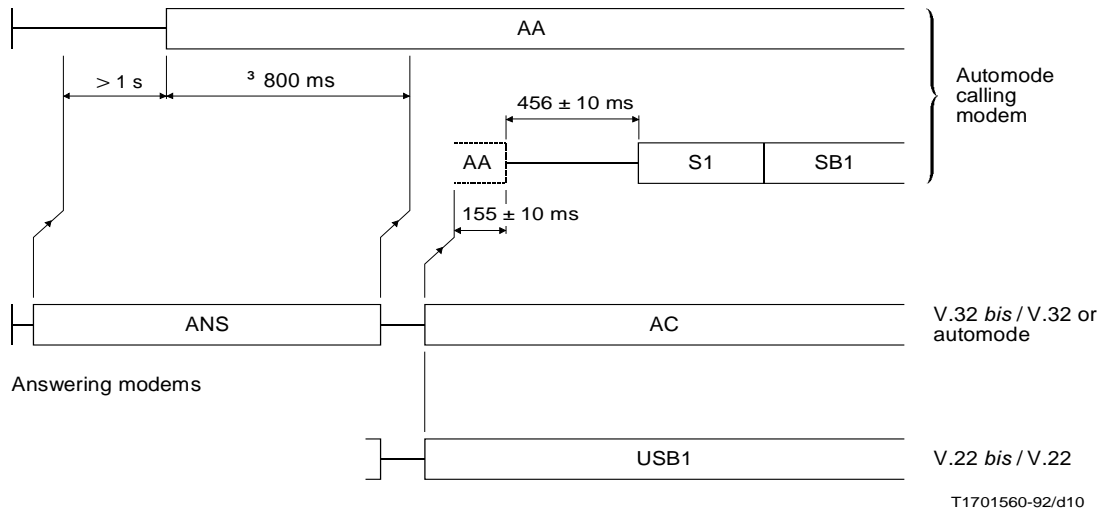

FIGURE A-1/V.32 bis
**Procedure when a calling automode modem measures at least 800 ms
of signal ANS after it has started transmitting signal AA**

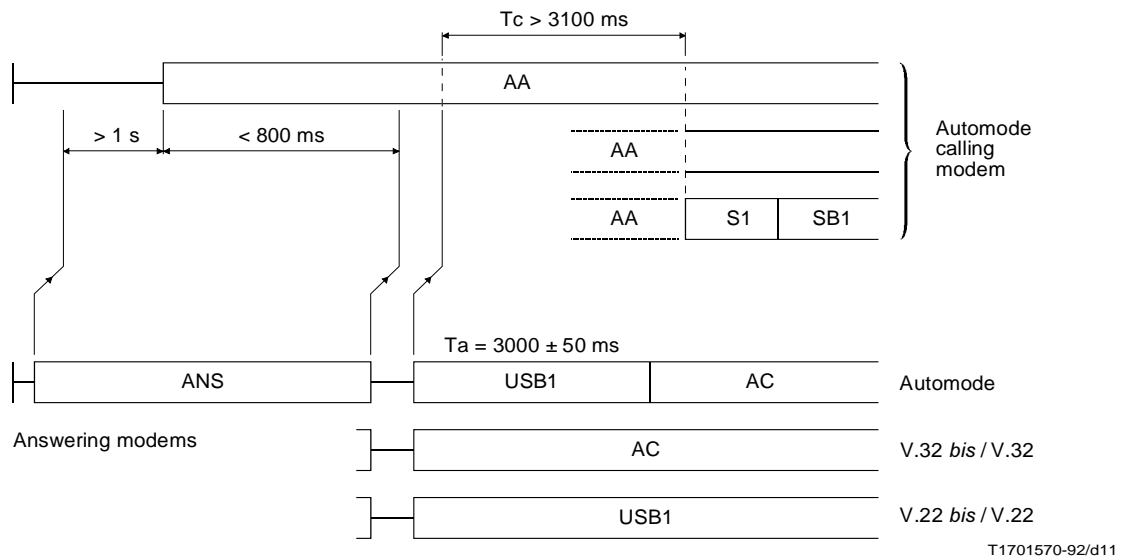

FIGURE A-2/V.32 bis
**Procedure when a calling automode modem measures less than 800 ms
of signal ANS after it has started transmitting signal AA**

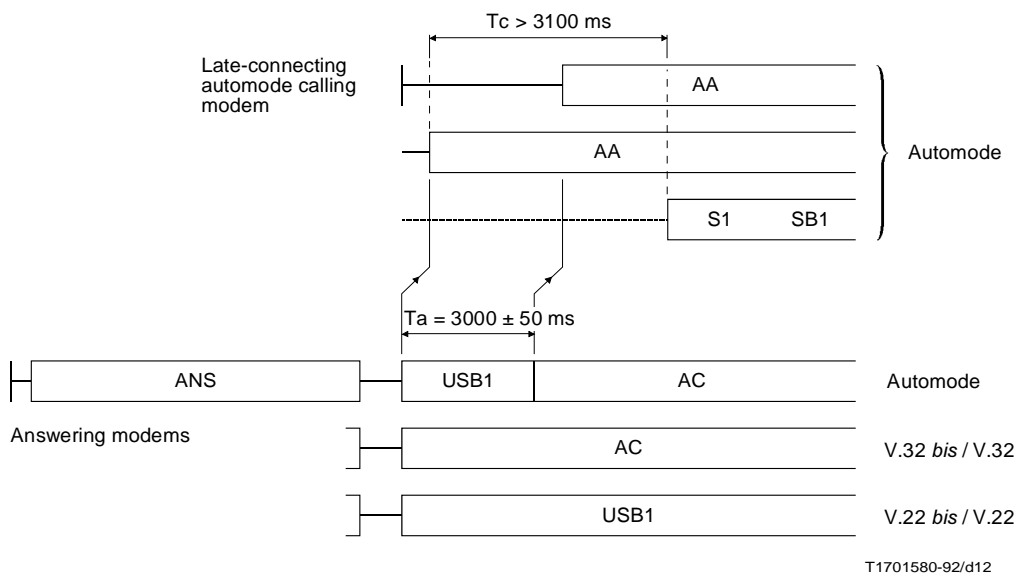

FIGURE A-3/V.32 bis

Procedure when a calling automode modem connects after the V.25 answer sequence

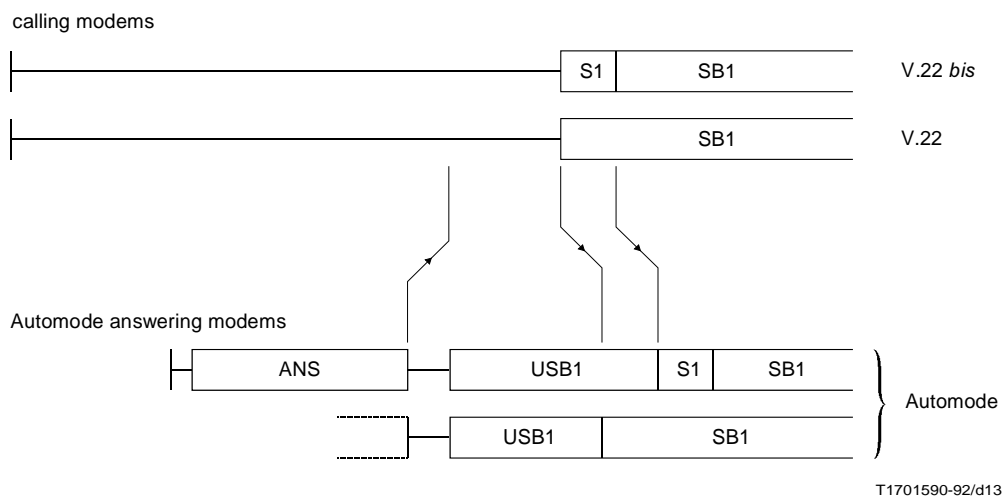

FIGURE A-4/V.32 bis

Answering automode modem interworking with a calling V.22 bis or V.22 modem